

REARS

Engine Drive Powerblast 33" single fan

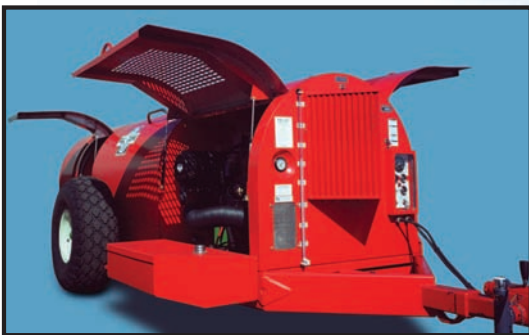

POWERBLAST



Top and inset, above, 500 gallon tank with standard frame, 33" fan.

At right, 400 gallon tank with narrow frame and 38" fan/housing.



500 or 600 gallon tank with standard frame

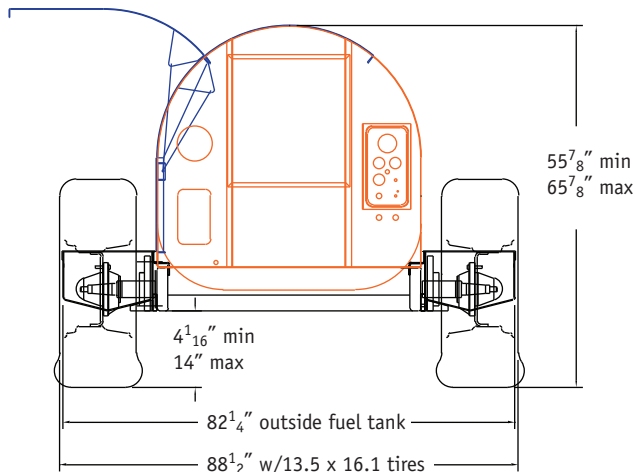

400 gallon tank with narrow frame

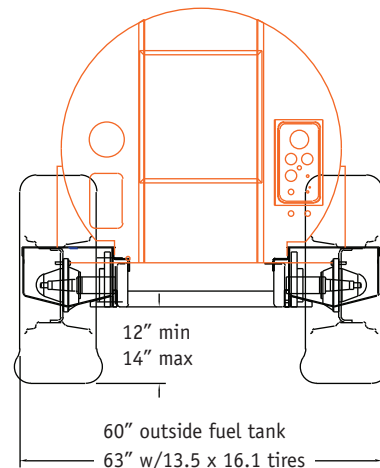

unit length 19' 10" 500 gallon standard or 400 gallon narrow

engine drive **powerblast** sprayer single **33"** diameter fan

John Deere *Powertech* 4.5L diesel engine
115 horsepower turbocharged

Electric throttle

Vibration dampener on flywheel
minimizes drivetrain vibration

Large surface easy clean radiator

50 gallon fuel capacity *500 & 600G units*
40 gallon fuel capacity *400G Narrow*



500 Standard w/33" fan



400 Narrow w/33" fan

33" diameter 9 blade stainless steel
axial flow fan operating @2200RPM

SS304 stainless steel blower housing

Electric fan clutch

Lower air scoops

Stainless steel tank: *500, 600, 400 Narrow*
stainless steel plumbing, lid assembly
stainless steel large paddle mechanical agitation
stainless steel tank rails, engine shroud

2"NPT Quick-Fill fittings front & rear of tank

Safety shut down system

Oil pressure

Water temperature

Control from the cab

Throttle

Spray manifold

Dump valve

Emergency Shut Down

Instrumentation

Ammeter

Tachometer

Oil pressure

Water temperature

Hour meter

Air cleaner service indicator

Multiposition axles or fixed offset

Tire options

Rears RPA centrifugal pump
80GPM/200PSI

Electric pump clutch

Electric spray controls

Electric dump valve

Suction line and discharge line strainers are
easily isolated for cleaning
Oversize suction line strainer with large surface
area screen element and Stainless Steel housing

Rollover nozzles with ceramic tips

Diaphragm check valves on each nozzle
for positive shut-off

Adjustable swivel hitch

Work lights

13.5-16.1	TERRA
14L-16.1	RIB
16.5L-16.1	RIB/TERRA
12.5L-16.1	RIB/TERRA
11.25-24	RIB



**For more information,
or the location of your nearest dealer,
please call 800.547.8925**