

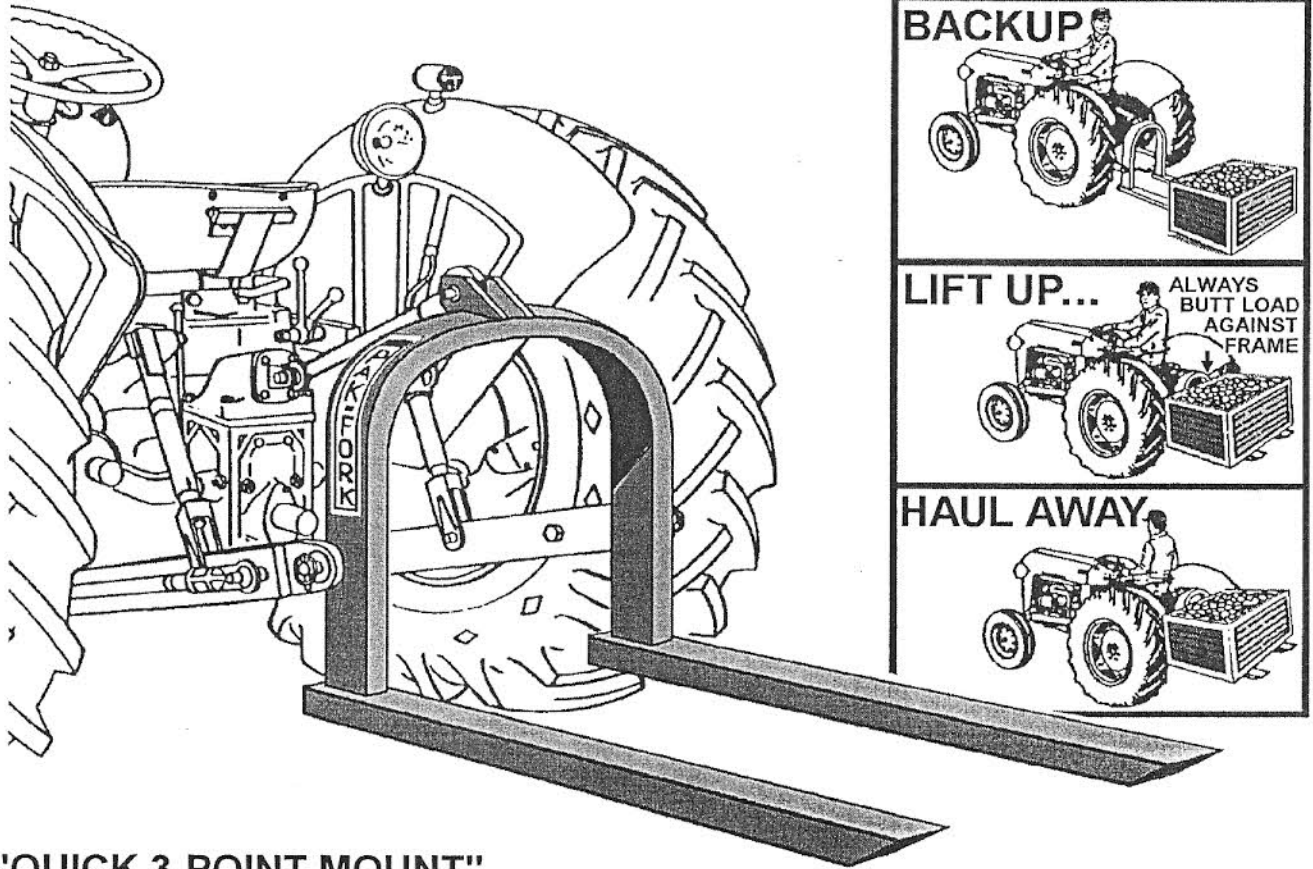

PAK-FORK

"LIFT CAPACITY: 1500 LBS @ 24" FROM LIFT PINS"



"QUICK 3-POINT MOUNT"

You'll find the Pak-Fork to be one of the handiest tools on the farm... Haul hay, feed, fence posts, fencing wire, tote boxes of fruit and vegetables, irrigation pumps, small sanitary buildings, etc. etc.

STRUCTURE: Fork width (center to center) 24-1/2"; length - 41". Constructed of sturdy 2" x 4" rectangular steel tubing. Approximate weight: 96 lbs.

LIFT HEIGHT: Lift height is limited only by the tractor's hydraulic 3-point lift.

BACK TILT: Using a standard (adjusted) top link, back tilt is automatic as forks are raised. If greater back-tilt is desired, a hydraulic cylinder can be used as the top link.

MOUNT PINS: Pak-Fork is available with Cat. 1 or Cat. 1 & 2 link pins for tractor 3-point hook up.

FOR YOUR SAFETY AND PAK-FORK LONGEVITY:

- NEVER use just the ends of the forks to lift an item.
- Butt load fully up against Pak-Fork A-frame.

DEALER:

Sept. 12, 1994-Litho U.S.A.

REAR'S MANUFACTURING COMPANY 1-800-547-8925 2140 PRAIRIE RD EUGENE, OR 97402