



1 Large mouth for ease of feeding. When cut height is zero, the feed opening is 17-1/4" with chain debris guard in place. Cut height is adjusted with a hydraulic cylinder.

234

Design the best field composting machine for your crop and available horsepower. All Rears choppers utilize a swath width angle shear bar (2) mounted to the inner flail housing in the blade path. Each blade passes the shear bar 35 times a second at 2100 RPM.

A row of stationary interference teeth (3) is available for increased shred quality if needed. Matched to the blade pattern, the knives pass between the teeth.

A 2-position rear recycling door (4) can be installed to recycle cuttings within the housing, increase shred quality and speed field composting of discharged material.

5

The FL940/FL946 crop chop knife is rolled to shape from alloy steel and heat treated for long edge life. The FL946 is durafaced, extending knife longevity and delivering excellent performance for the dollar. Blades are reversible. Tip speed is 13000FPM. Available without durafacing, FL940.

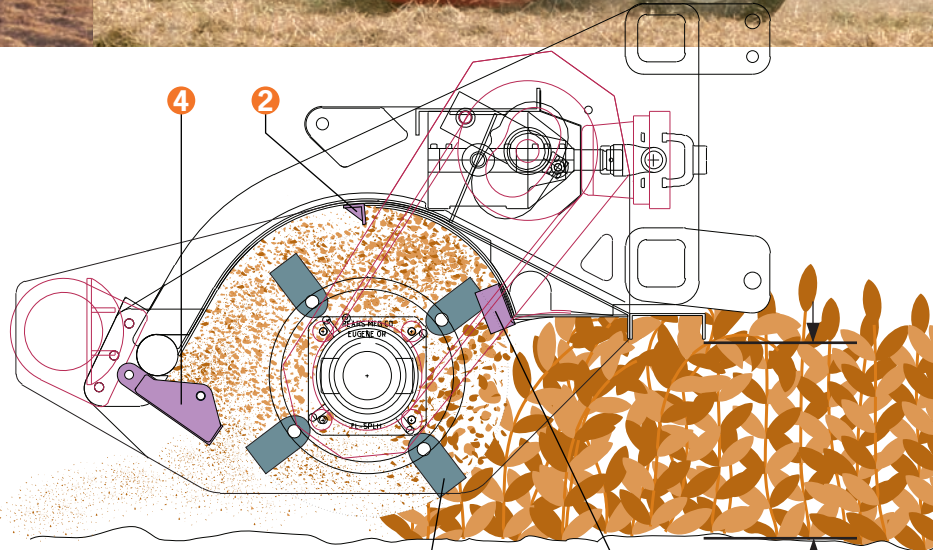
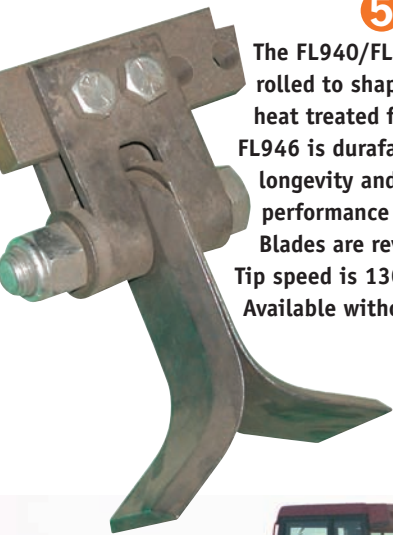

6

Rears Pul-Chopper utilizes our Constant Velocity Hitch for superior tracking: keep on running through 90° turns.

- Telescoping driveline eliminated protects tractor PTO
- Utilizes the tractor 3-point hitch removes the requirement to establish a hitch pin center point

Rears built and field tested for more than 30 years.

Other hitch systems available

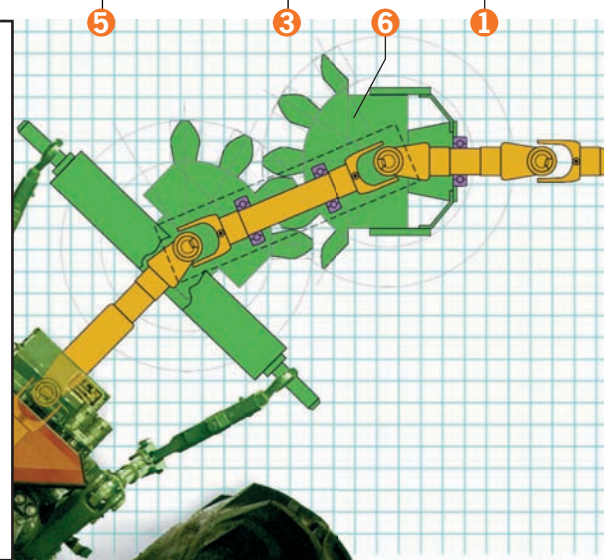

7

The unique casters on Rears Pak-Chopper provide optimal maneuverability for a 3-point mount system: your tractor's turning radius is uncompromised. 180° and 360° caster options. Extended axle available, illustrated above, to allow caster placement outside of flail housing to match row crop beds.

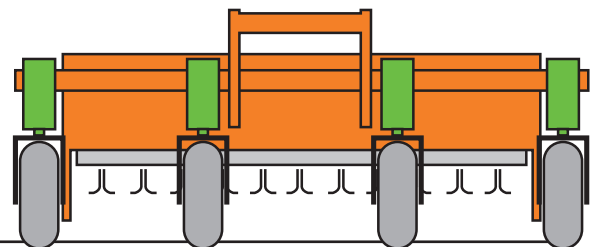

S Series	Pak-Chopper		Pul-Chopper	
Available swath	7' - 22'		10' - 22'	
Overall width	Single drive + 12" Dual drive + 24"		Dual drive + 24"	
3-point mount	Cat III or IIIN Free-link or Quick Hitch, standard Other options available		Cat II or III Free-link or Quick Hitch Other options available	
Constant Velocity Hitch**			Heavy Plate Construction 1.25" heat treated pivot bushings 1.5" 17 spline heat treated 1045 drive shafts 55 series U-joints	
Cut height	Call with your requirements			
PTO speed	7' - 11' 12' +	540 RPM* 1000 RPM	10' - 11' 12' +	540 RPM* 1000 RPM
Gearbox	1:1.875 1:1.35 Input Shaft Output Shaft		540 RPM 1000 RPM 1.75" 20 spline 1.375" 21 spline	
Gearbox cooling fan	7' - 11' 12' +	Optional Included	10' - 11' 12' +	Optional Included
Belt drive	7' - 11' 12' +	Single Drive* 5/5VX notched/5 groove Dual Drive 5/5VX notched/5 groove	10' - 11' 12' +	Single Drive* 5/5VX notched/5 groove Dual Drive 5/5VX notched/5 groove
Belt tensioner	OMT300 Quick draw tensioner adjusts center distance between drive sheave and rotor sheave			
PTO drive	Shielded, low friction rolled spline shaft 55 series U-Joints Overrunning clutch***		Shielded, low friction rolled spline shaft 55 series drive train 55 series U-Joints Overrunning clutch***	
Casters	7' - 11', 2qty; 12'+, 4qty 180° or 360° casters 9.5L x 15 tires standard			
Struts	7' - 11', 2qty; 12'+, 4qty 9.5L x 15 tires		10' - 11', 2qty; 12'+, 4qty 9.5L x 15 tires standard, other options available	
Rotor bearing	2.44" double spherical roller bearing Rears grease labyrinth protection Lubrication points outside belt housing			
Rotor construction	8-5/8" diameter mandrel 2.44" dia. rotor shaft, 1045 carbon steel			
Rotor speed	1720 - 2100 RPM crop dependent			
Center bearing	13' - 22' units Narrow double spherical roller bearing Center-swath placement, standard: call for options			
Housing	Double wall 3/16" plate			
Debris guard	Chain guard standard, additional belt guards available			
Field Compost Package	Recycling door	Optional 2 position recycling door traps cuttings		
	Angle shear bar	Standard internal mount shear angle, width of swath		
	Shear channel	Optional shear channel with hardfaced teeth		

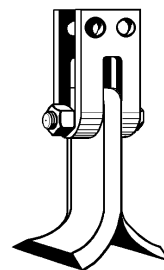

FL940/946

Crop/chop knife
Reversible
4 or 6 assy/ft
FL946 is durafaced

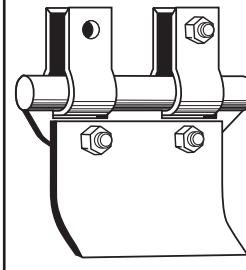

FL950/953

Scalping blade
4 assemblies/ft
High suction design for material lift
FL953 is durafaced

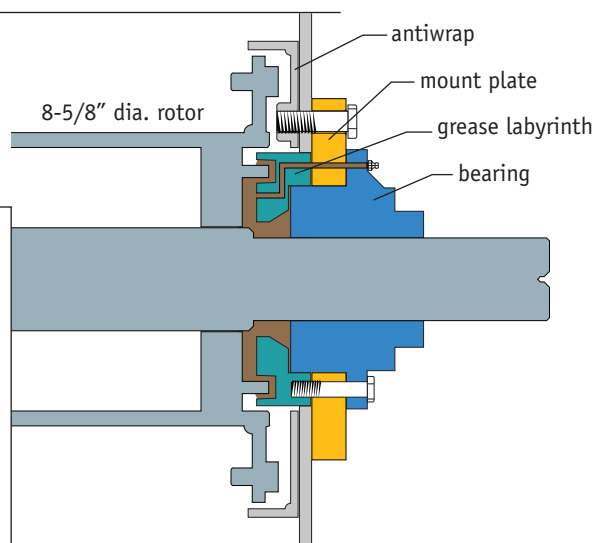

* standard delivery configuration can be changed
** other hitch systems available
*** 55 series overrunning clutch standard on 12' units and larger; option for narrower units. 77 series available.



For more information,
or the location of your nearest dealer,
please call **800.547.8925**